

**XTR-1200 SURVEILLANCE / SOLAR LIGHT TOWER**

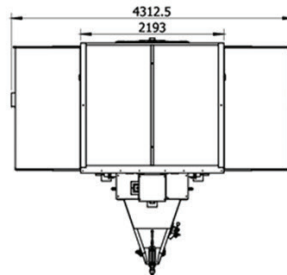

PRODUCT SPECIFICATION	
Product Name:	XTR-1200 SURVEILLANCE / SOLAR LIGHT TOWER
Usage:	SURVEILLANCE / SOLAR LIGHT TOWER
Brand:	XTR-1200
FEATURES	
Run Time:	Continuous discharge time of 28 hours when fully charged
Time proportion of charge and discharge:	1:2
Wind Rating Speed:	100kph
Protection Level:	IP65

**ARCHITECTURAL DRAWING**

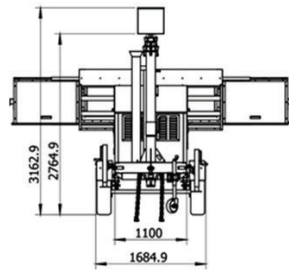
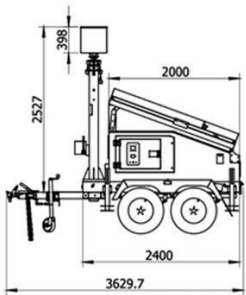
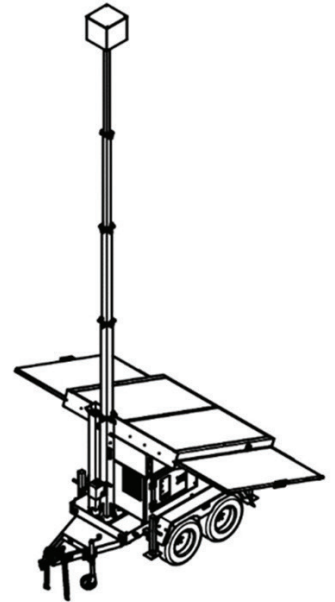
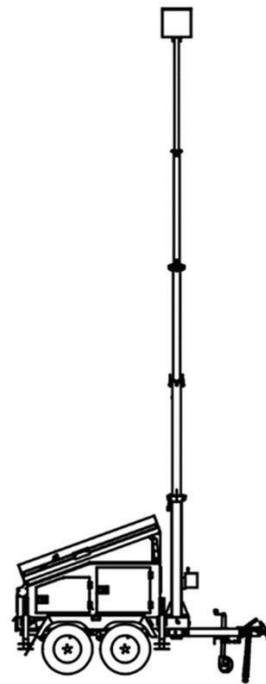
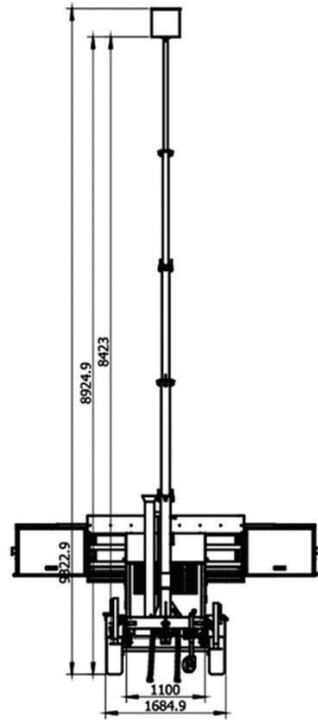
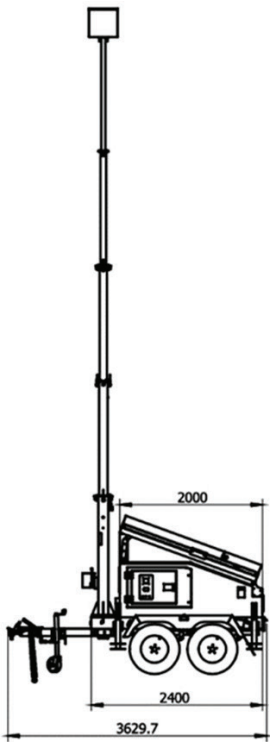

Brand:	XTRAVISION
Product Name:	XTR-1200 Surveillance / Solar Light Tower
<b>FEATURES</b>	
Run Time:	Continuous discharge time of 28 hours when fully charged
Time proportion of charge and discharge:	1:2
Wind Rating Speed:	100kph
Protection Level:	IP65
<b>DIMENSIONS &amp; WEIGHT</b>	
Trailers Size In Millimeters Including Weight:	2570Length X 2300Width X 2350Height Weight 2110Kg Mast
Size(Weight Is Included In Trailer):	2350Length X 540Width X 560Height
Mast Height From Ground When Erected:	9 Meters
<b>SOLAR PANEL AND BATTERY</b>	
Solar Panel:	325watt X 4 Monocrystalline Silicon
Battery:	200Ah X 8 Maintenance Free
<b>TRAILER</b>	
Axle:	Double SABS Braked
Tire:	195XR15
Drawbar:	A-Type Drawbar with Grating Plate
Brake System:	Dual Disc Break System SABS
Shock Absorber:	Double Eye Leaf Spring
Tail Lamp:	Sabs Standard
Outtrigger:	7000LBS Jack And High Strength Square Tub
<b>ELECTRICAL PARTS/ CABLES (ALL ELECTRICAL PARTS HAVE UL CERTIFICATION)</b>	
Solar Controller:	MPPT/ LCD Mt50 Interface
Safety Cut Off:	DC Power Lock Out Breaker
Breaker:	DC Dual/ Double Pole Isolator
Network Switch:	12VDC Industrial Field Hardened Network Switch
Power Supply:	Power Supply 24VDC to 12VDC
Cable Harness:	wires 2xCAT-6 cable, 1x220VAC cable, 1x8 core multicore 1.5mm cable
Inverter:	12VDC to 220VAC 500Watt (Standard)
<b>OTHER/OPTIONAL</b>	
Stainless Steel:	Optional
Inverter:	Optional Sizes can be fitted (must be specified when ordered)
Diesel Generator Backup:	Optional